

Storefront Installation Guide General Notes:

1. Check Contract Documents and Shop Drawings. Understand and clarify any Field Verify Notes and approvals of drawings and products to be familiar with the project. Installation instructions are intended to be a reasonable guideline for installation of product as based on testing and common conditions. Conditions on a project may vary and deviations or special instructions should be defined in the shop drawings. Shop Drawings should take precedence and define project specific product and installation.
2. All materials need to be inventoried to be certain everything required for installation is accounted for.
3. Materials need to be installed plumb, level and true.
4. Work from project defined bench marks like center column lines, finished floors, or mullion spacing as defined by the Architectural drawings and the General Contractor.
5. All sealants need to be compatible with all materials. The Glazing Contractor and /or General Contractor are responsible for supplying sealants and submitting any sealant compatibility and performance documentation.
6. Isolation of dissimilar materials “For example Aluminum and uncured Concrete,” should be prepared using bituminous paint or zinc chromate coating or approved equal.
7. Protection and cleaning of materials are the responsibility of the Glazing and General Contractors. (Reference AAMA documentation, and care and maintenance.)
8. Diversity of Federal State and local Building Codes are the responsibility of the Architect, Owner and customer to interpret compliance for the fenestration products used on the project. Boyd Aluminum is only a material supplier.
9. Boyd Aluminum is the material supplier of the fenestration product defined in the drawings and contract documents. Only fasteners and accessories within the system are supplied. Anchors, Sealants and fasteners to the surrounding conditions should be defined on the shop drawings and normally the responsibility of the Glazing Contractor.
10. Due to changing fenestration parameters and evolving product lines, Boyd Aluminum reserves the right to change detailing and documentation commensurately without notification.

Boyd Center Set Storefront is available in thermal and non-thermal systems. Our thermal system is designated B450 and our non-thermal is designated B350. Both are available for assembly using either the screw spline or shear block fabrication methods.

Figure: A

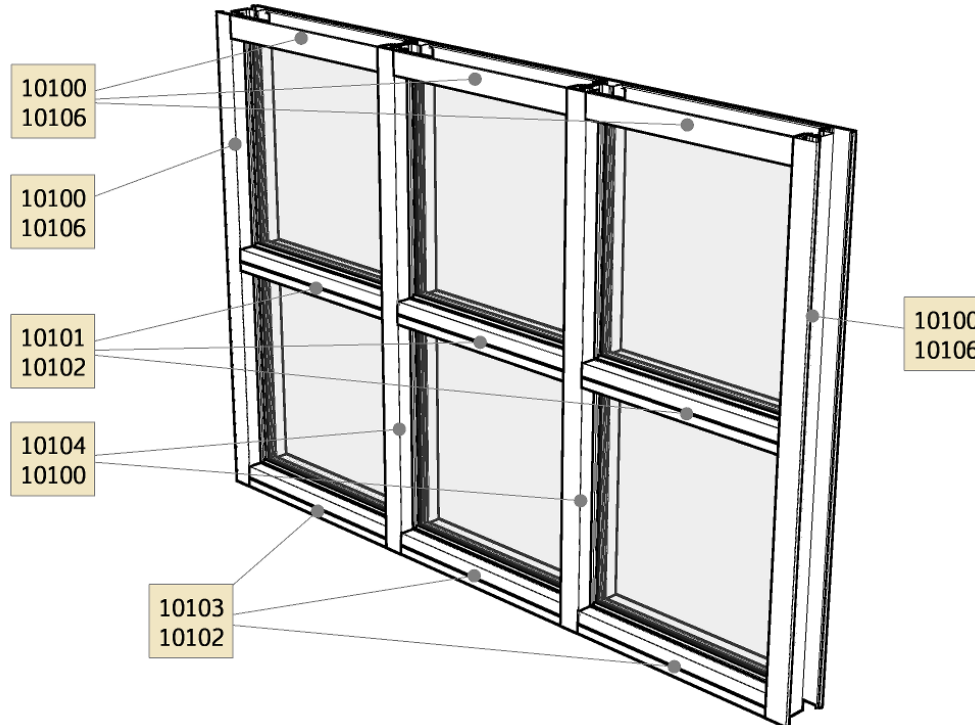

This illustration (Figure: A) shows a typical outside glazed elevation for the Boyd B450 system.

- Heads - 10100 and 10106
- Horizontals - 10101 and 10102
- Sills - 10103 and 10102
- Jams - 10106 and 10100
- Mullions - 10100 and 10104
- Sub Sill - 10105

Figure: B

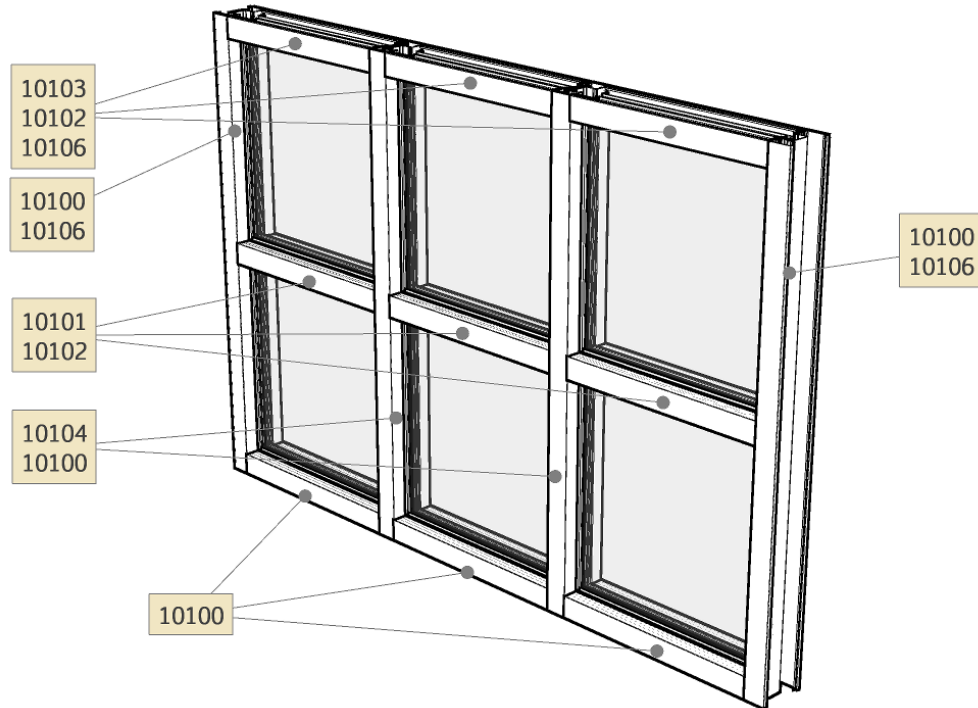

This illustration (Figure: B) shows a normal inside glazed elevation for the Boyd B450 system.

Heads - 10103 and 10102 and 10106

Horizontals - 10101 and 10102

Sill - 10100

Jams - 10100 and 10106

Mullions - 10100 and 10104

Sub Sill - 10105

Storefront Frame Fabrication

Step 1. Measure the Opening

- Measure the width of the opening at the top, middle, and bottom of the opening and use the smallest length to calculate your frame width.
- Then measure the height of the opening along several places on the length of the opening and use the smallest height to calculate your frame height.
- Make sure to allow extra clearance if necessary for shimming and sealant for building tolerances and movement per project requirements.

Step 2. Verticals cuts

- Verticals are the height Frame Size, (FS) - .500" to place on Sub sill.
- Verticals typically run through.

Step 3. Cut the Sub Sill to Size

- The sub sill is a horizontal that runs across the entire base of the opening to collect and expel water from the system.
- Cut your Sub Sill to the frame width figured in Step 1+any widths you allowed for shimming and sealant.
- Minimum width of sub sill is Frame Size, (FS) + .25".
- Sub Sills longer than 24 feet long must be spliced together. Expansion may require more frequent splicing, and expansion mullions per project requirements.

Step 4. Horizontal Cuts

- Cut horizontal members to Day Light Opening, (DLO).
- Cut glass stops to DLO-.062".

Step 5. Drill Assembly Holes on Vertical Members

- Drill Jigs are available for easier and faster fabrication.
- (Figure: C) Screw Spline
 - Use a .201 diameter #7 drill to drill clear holes on screw spline installation
- (Figure: D) Shear Block
 - Use a .144 diameter #27 drill pilot holes for shear block installation

Figure: C

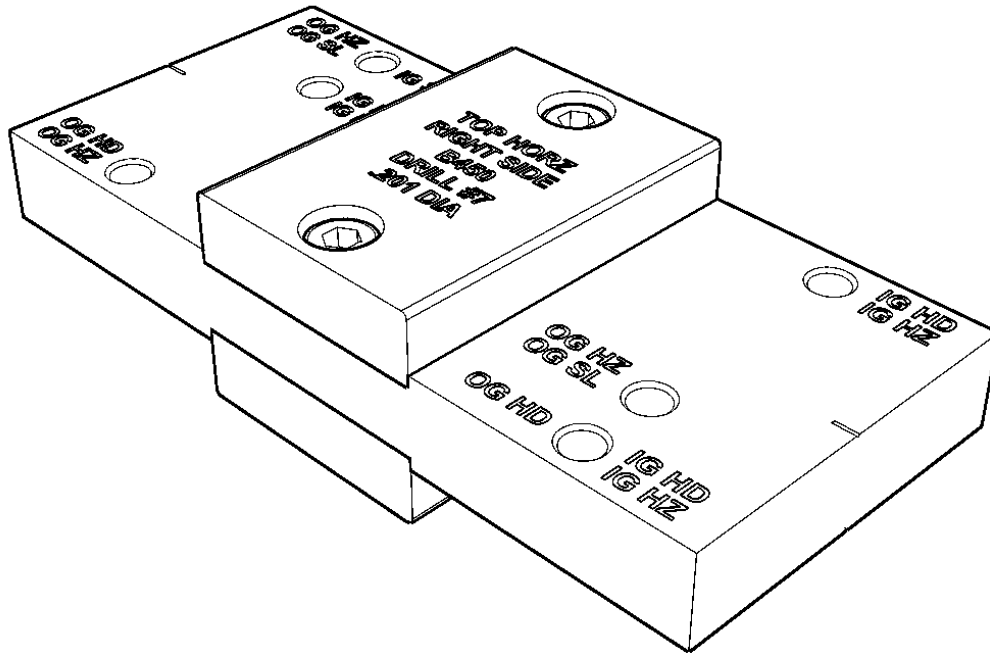
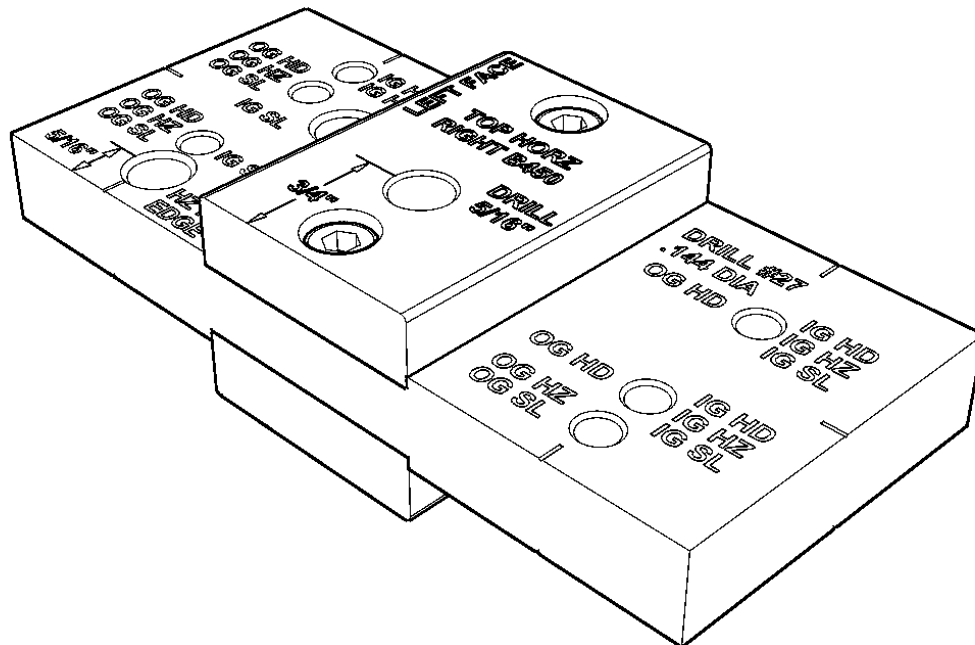

Figure: D



Let's Shine.

800.737.2800 • fax 417-862-1232 • BoydAluminum.com

©2014 Boyd Aluminum Manufacturing. The Boyd sunburst and logotype are trademarks of Boyd Aluminum Manufacturing. All rights reserved. Due to continued product research, specifications are subject to change without notice.

SFIG-5

062514

Inside Glazed Screw Spline

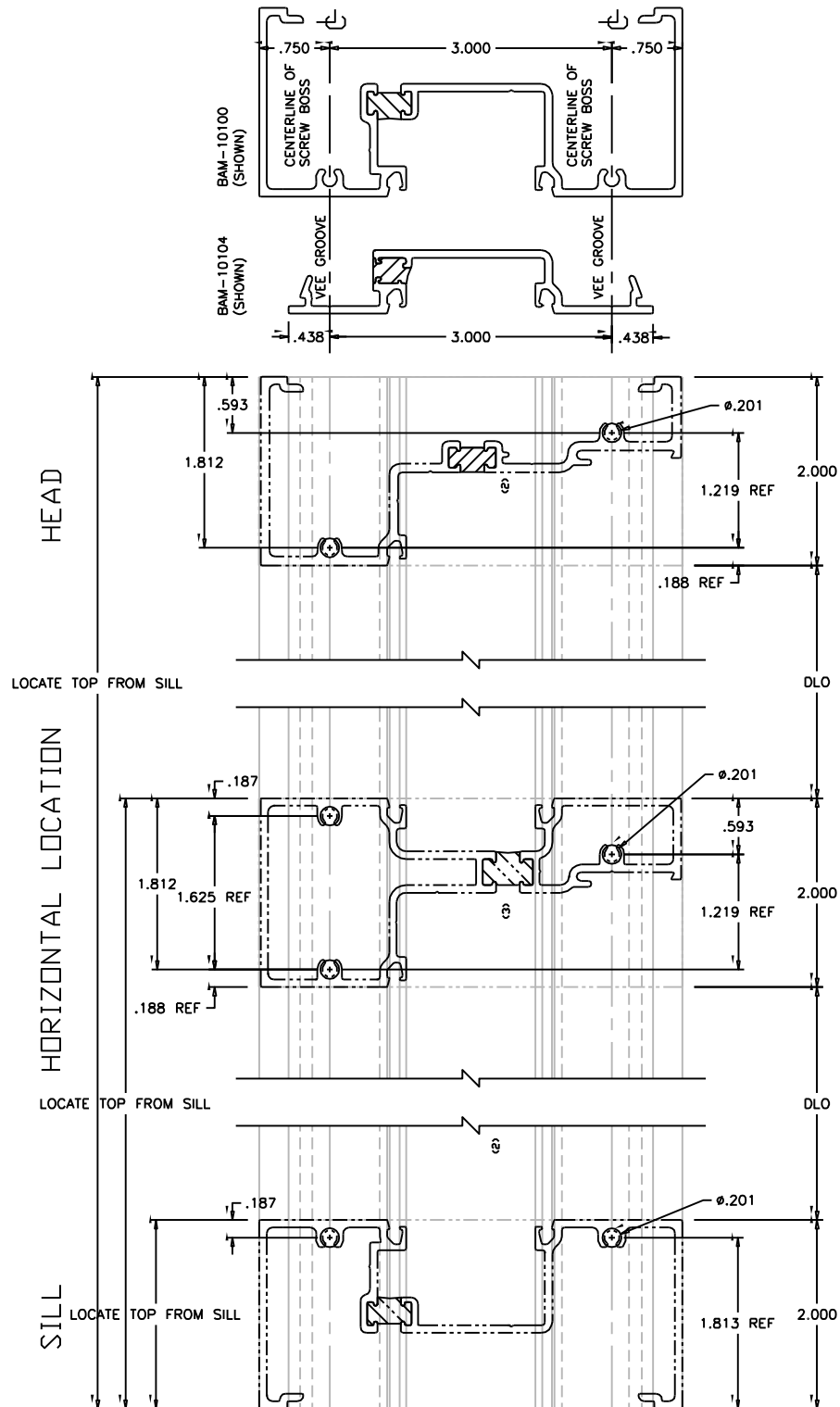

Let's Shine.

800.737.2800 • fax 417-862-1232 • BoydAluminum.com

©2014 Boyd Aluminum Manufacturing. The Boyd sunburst and logotype are trademarks of Boyd Aluminum Manufacturing. All rights reserved. Due to continued product research, specifications are subject to change without notice.

SFIG-6

062514

Outside Glazed Screw Spline

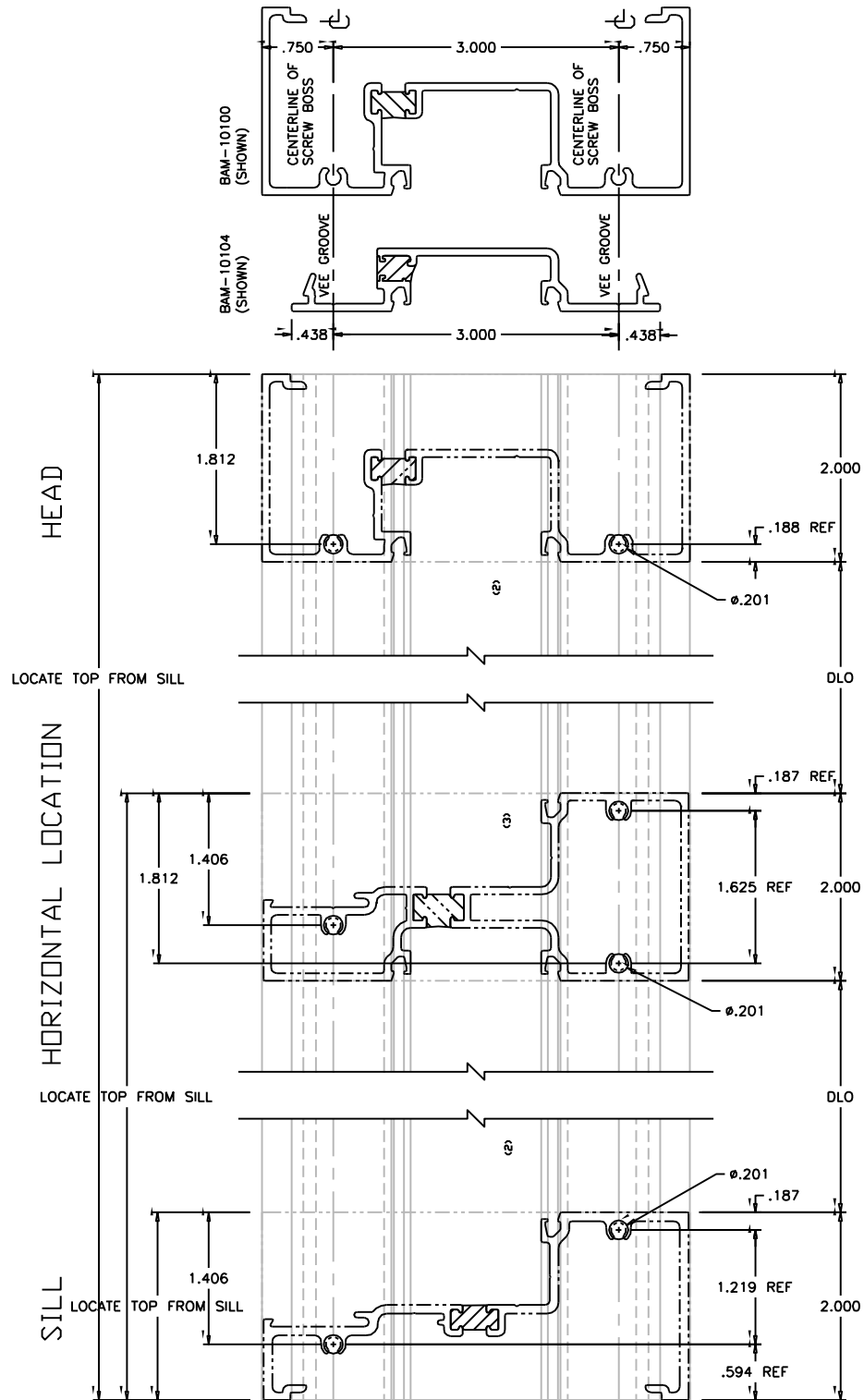

Let's Shine.

800.737.2800 • fax 417-862-1232 • BoydAluminum.com

©2014 Boyd Aluminum Manufacturing. The Boyd sunburst and logotype are trademarks of Boyd Aluminum Manufacturing. All rights reserved. Due to continued product research, specifications are subject to change without notice.

SFIG-7

062514

Inside Glazed Shear Block

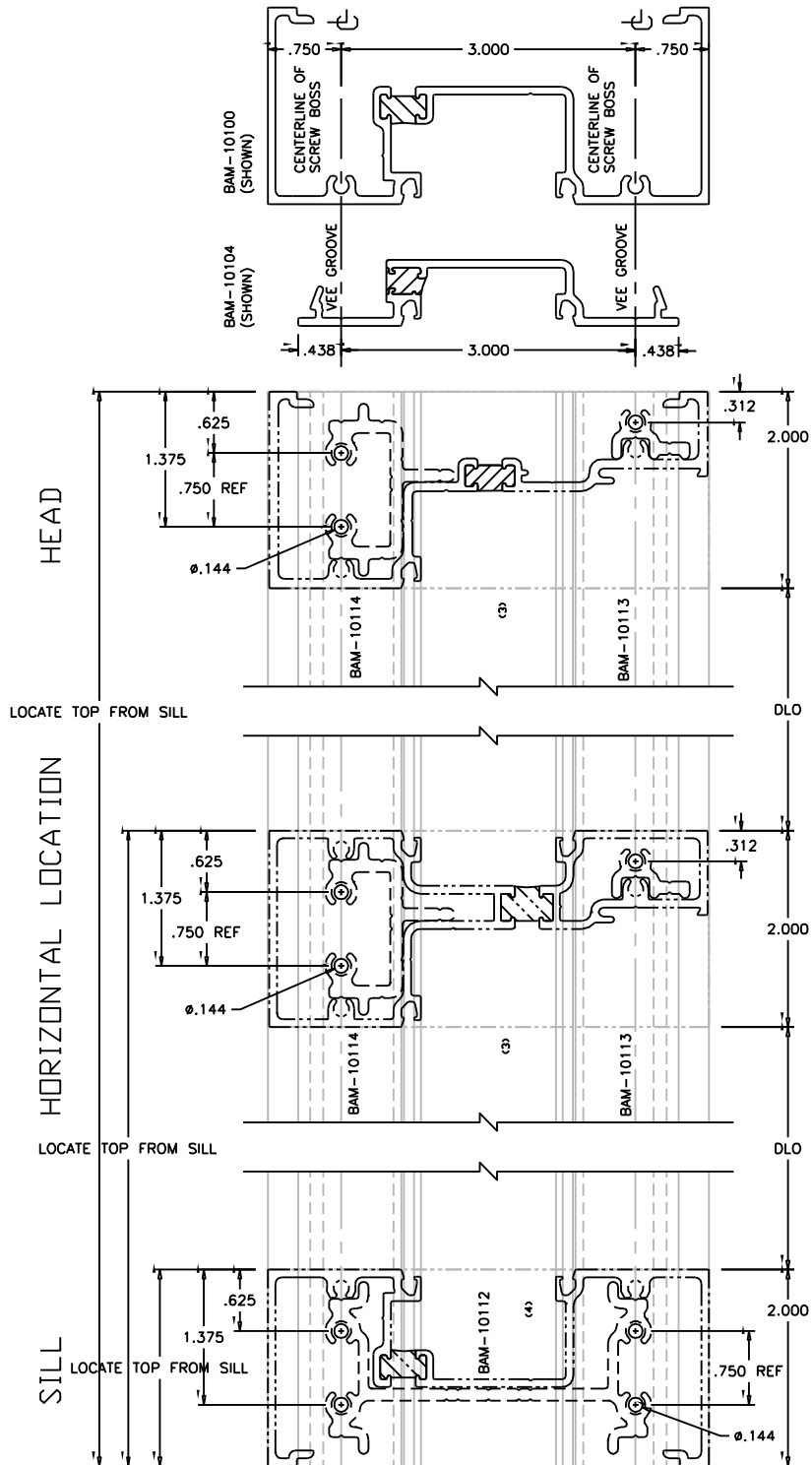

Let's Shine.

800.737.2800 • fax 417-862-1232 • BoydAluminum.com

©2014 Boyd Aluminum Manufacturing. The Boyd sunburst and logotype are trademarks of Boyd Aluminum Manufacturing. All rights reserved. Due to continued product research, specifications are subject to change without notice.

SFIG-8

062514

Outside Glazed Shear Block

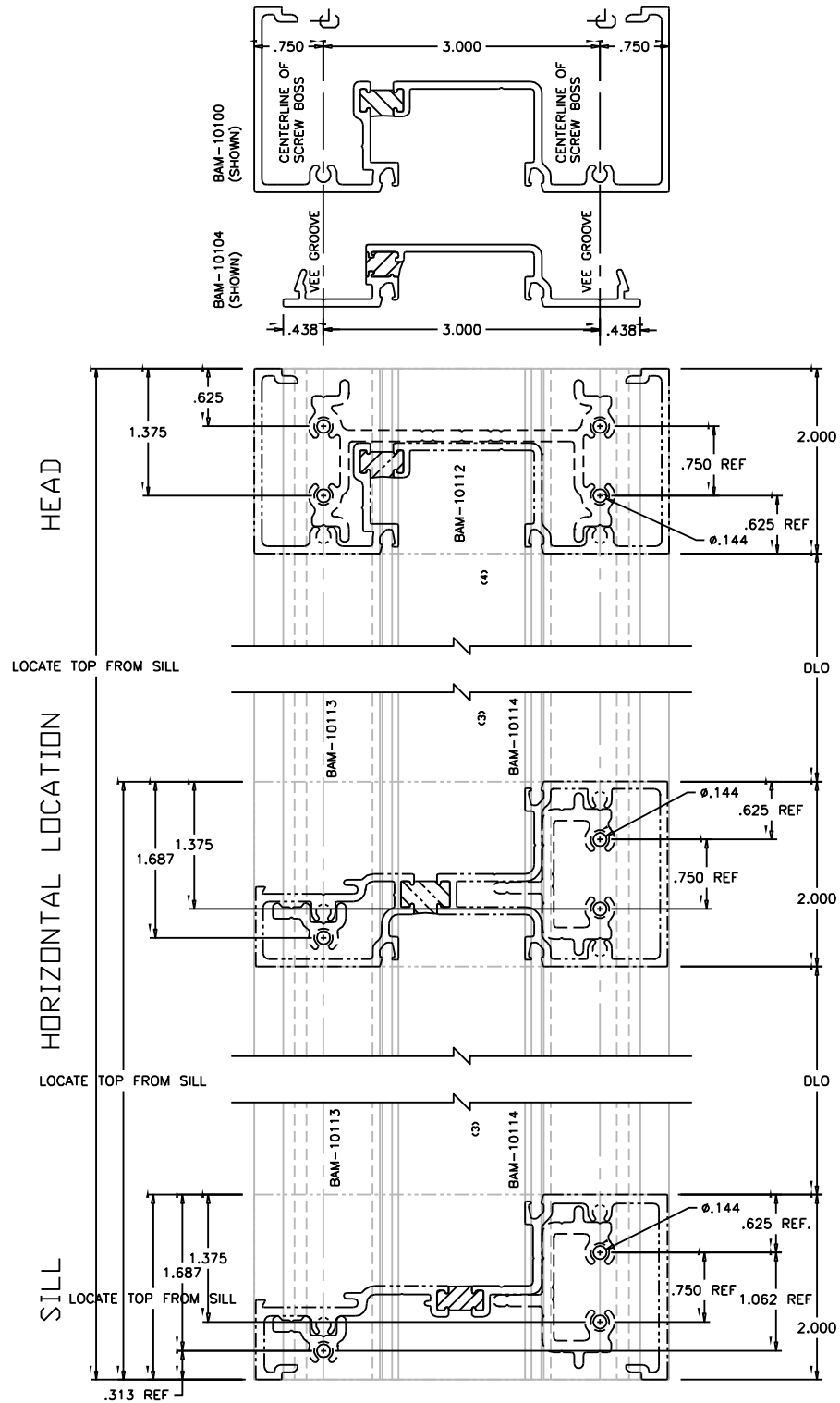

Let's Shine.

800.737.2800 • fax 417-862-1232 • BoydAluminum.com

©2014 Boyd Aluminum Manufacturing. The Boyd sunburst and logotype are trademarks of Boyd Aluminum Manufacturing. All rights reserved. Due to continued product research, specifications are subject to change without notice.

SFIG-9

062514

Step 6. Drill Weep Holes in Sub Sill and Apply End Dams.

- Drill 2 weep holes .25" diameter 24" on center at Sub sill. (Min. 2 per lite, 6" from verticals.)
- Before fastening in the end dam make sure you butter sealant to the end of the sub sill so it bonds with the end dam.
- Screw the end dam to the sub sill using two #10 x 1/2 PHL FH SMS.
- Make sure after fastening in the end dam you apply sealant on the head of the screws to "Tool and Seal All Openings."

Figure: E

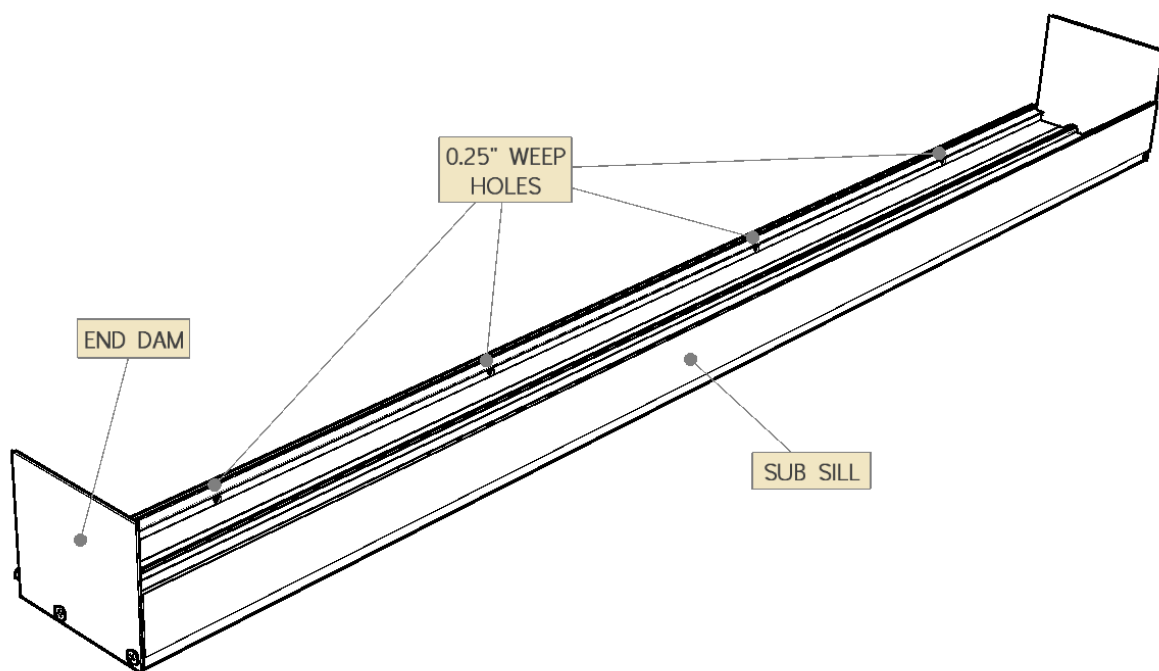

Step 7. Drill Holes in Vertical Member for Shear Blocks.

- Unique from screw spine assembly; pinning holes are drilled in the horizontals for the shear block construction.
- Shear blocks are fastened to the vertical members with screws.
- Butter ends of shear blocks with sealant before fastening to the verticals.
- Drill Jigs are available for easier and faster fabrication.
- Use a .144 diameter #27 drill to drill holes.
- Drill holes in Horizontals to accept pinning screws. (Do not oversize countersink.)

Storefront Installation

Step 1. Splicing the Sub Framing.

- Splice the Sub framing as required per job site and or thermal expansion requirements.
- Splice sleeves are required at splice joints.
- As required use thin silicone splice sheet material.
- Lay a bead of sealant in the expansion joint and around the edge of where the splice sleeve will be placed, positioned and embedded.
- After the splice sleeve is in place apply additional sealant around the perimeter of the sleeve. (Tool and seal all openings.)

Figure: F

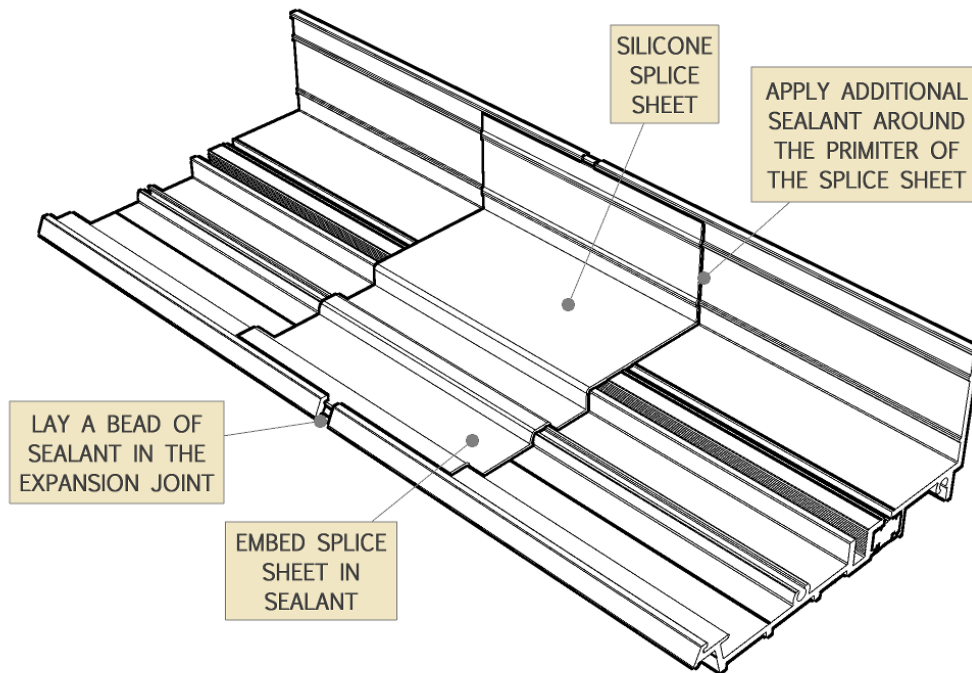

Step 2. Anchor and Seal the Sub Sill.

- Start installation at the wall jamb, center or bench mark.
- Apply silicone to the end dam contact areas.
- Inspect and seal all openings.
- Set the sub sill into place and temporarily shim both end dams to push it tight against the jamb.
- Shim and seal unit as needed sealing all openings.
- Anchor the sub sill per project requirements and drawings. Make sure to cap and seal the anchor bolts with sealants and do not drill through the thermal barrier.
- Anchor holes should be loose or slotted to allow for job site expansions.
- Apply and tool a bead of sealant along the back leg of the sill from end to end, across the sub sill.

Figure: G

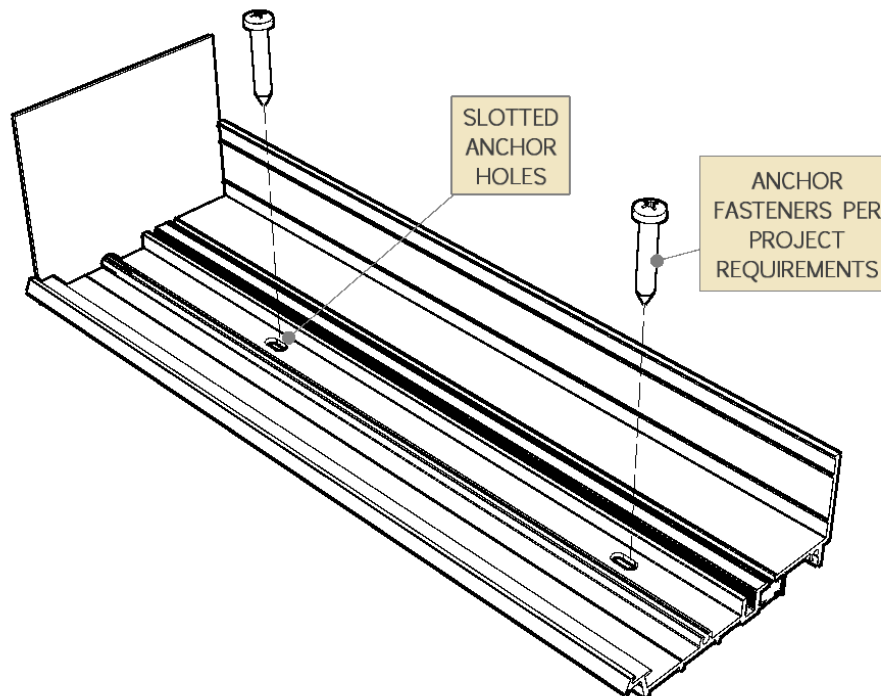

Step 3. Attach the Horizontals to Verticals.

- Fill the gasket reglets on the vertical between the Horizontal's gasket reglets. Be careful not to get sealant into the area of the gasket reglet to be used.
- Butter the contact edges of the horizontals with sealant.

Figure: H

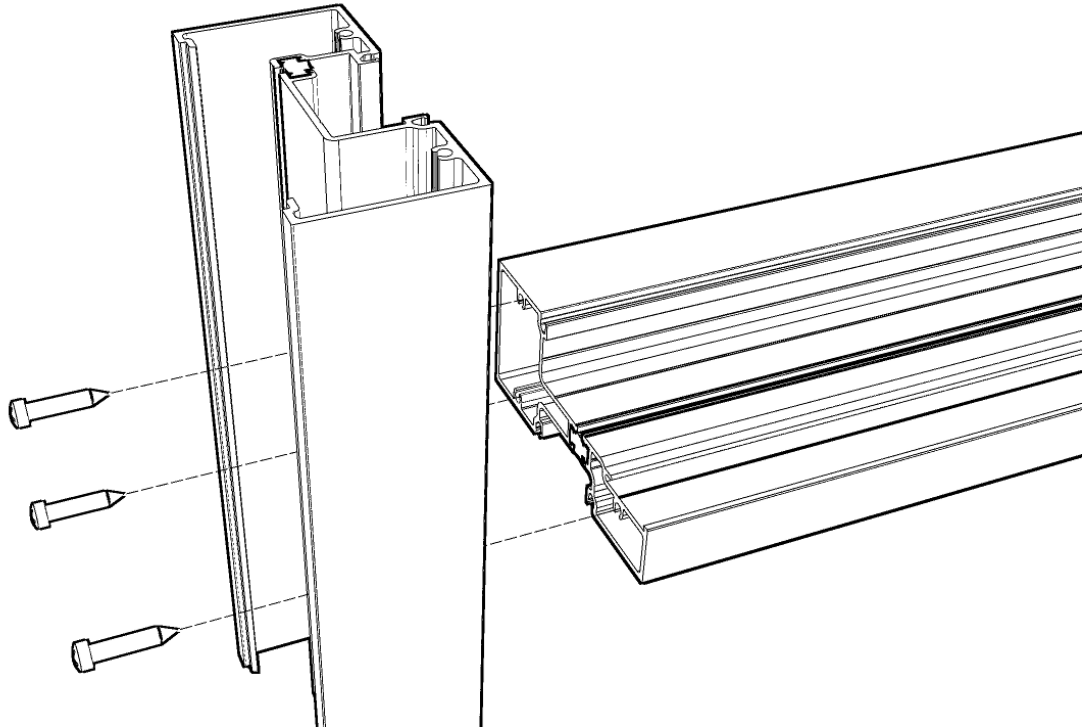

- Secure horizontals to verticals using #10 x 1-1/4 PHL PH SMS SS Assembly Screws.
- Start with jamb assembly.
- Make sure one side is a male vertical and the other side is a female vertical.
- Each lite must include one deep pocket and one glazing stop. (Tool and seal all openings.)

Step 4. Attach the Horizontals to Verticals.

- Fill the gasket reglets on the vertical between the Horizontal's gasket reglets. Be careful not to get sealant into the area of the gasket reglet to be used.
- Butter the contact areas of the shear blocks then secure them to the verticals using #10 x 1-1/4 PHL PH SMS SS Assembly Screws.
- Butter the contact areas of the horizontals then slide them onto the shear blocks.
- Secure horizontals to the shear blocks using our #10 x 1/2 PHL FH SMS SS shear block pin screw.
- Apply sealant to the shear block pin screw heads. (Tool and seal all openings.)

Figure: I

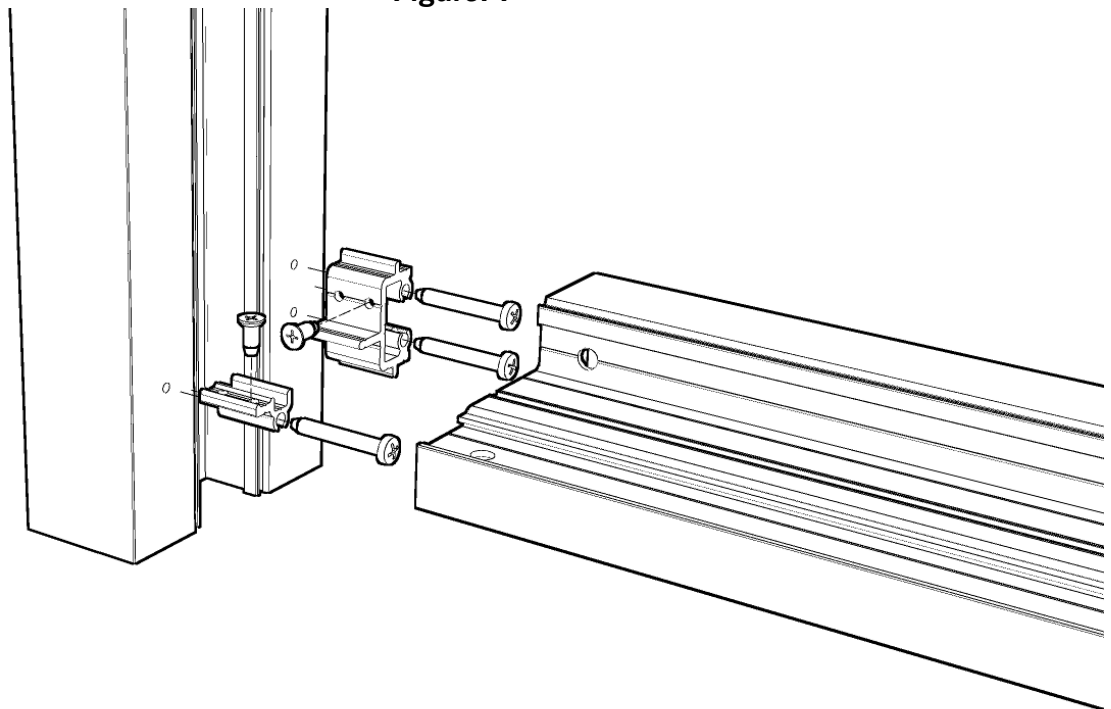

Step 5. Steel Reinforcing (Optional)

- Cut the steel reinforcement to allowable mullion length minus required clearance and paint the ends to prevent rust.
- Insert the steel into the mullion.
- Drill through the pocket of the mullion and match drill the steel as required by shop drawings or job calculations.
- Remember the steel is attached per job requirements just prior to snapping the vertical members together. (Tool and seal all openings)

Figure J

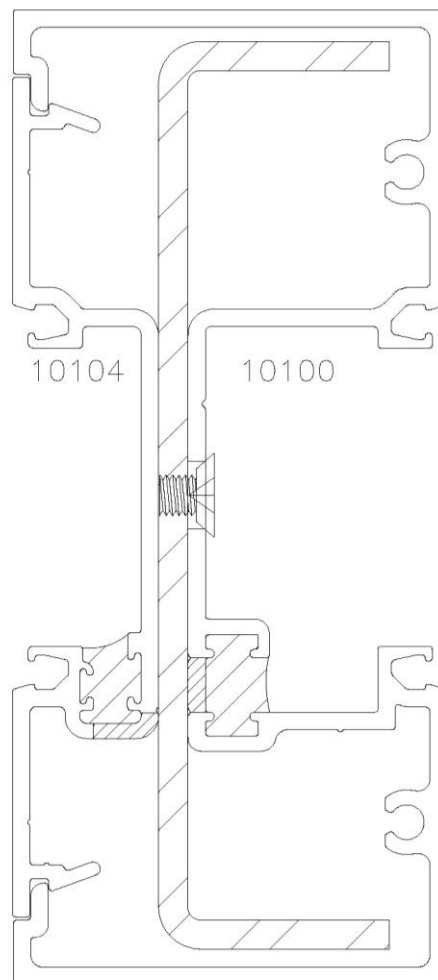

Step 6. Install the Units

- Butter the end of the verticals with sealant.
- Each unit must have one vertical deep pocket to allow for glazing. Remember to never have two shallow pockets facing each other.
- Apply a bead of sealant on the sub sill flashing leg
- Begin Installation at one jamb and work toward the other tilting the unit and setting it on the flashing. Then stand the unit up and continue to anchor in place.
- If using shear block assembly, set the units into the opening.

Figure: K

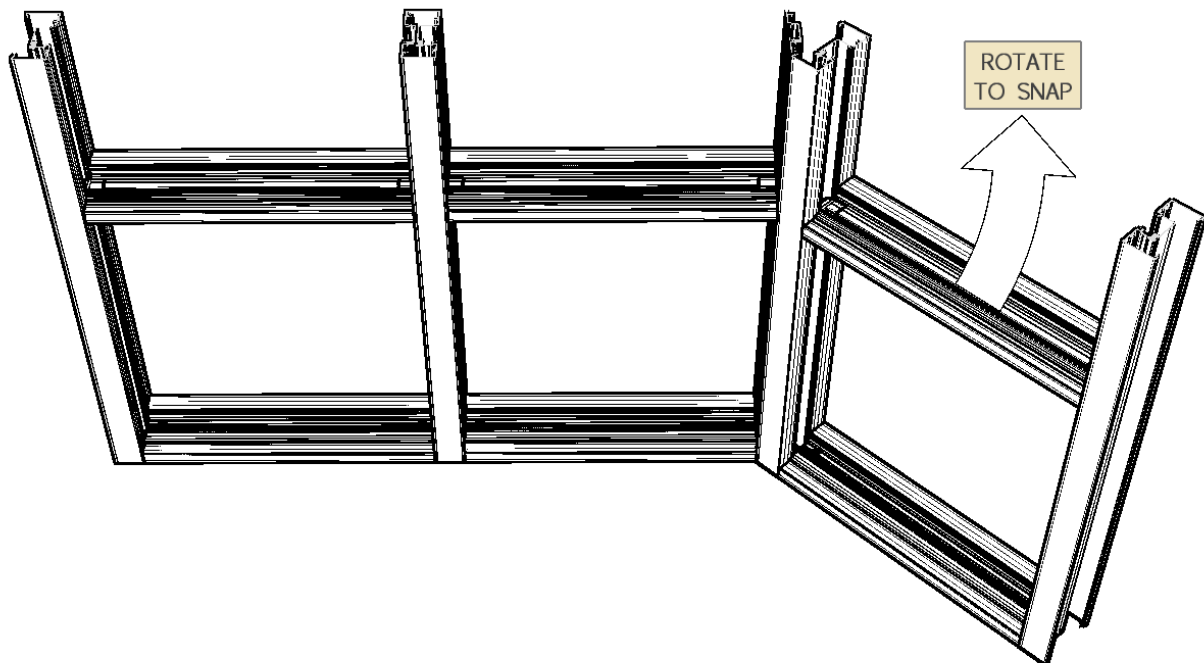

- Apply shims as required. (Tool and seal all openings.)
- At least a 3" frame filler at all anchor locations is recommended.
- Secure through glazing pocket and filler and anchor to the opening.
- (Caution anchors in glazing pockets may require Countersinking.)
- Make sure you refer to shop drawings for appropriate anchor locations.
- Cap seal and apply perimeter sealant per sealant manufacturer's instructions.
- Tool and seal all openings.

Glazing

Glazing sizes: (Always round glass down to the nearest .062")

B450 Glazing Size = DLO + .875"

B350 Glazing Size = DLO + .6875"

Step 1. Seal horizontals to verticals.

- Be certain the glazing reglets are filled in between Horizontal glazing reglets in the unused area.
- Butter the end of the verticals with sealant.

Figure: L

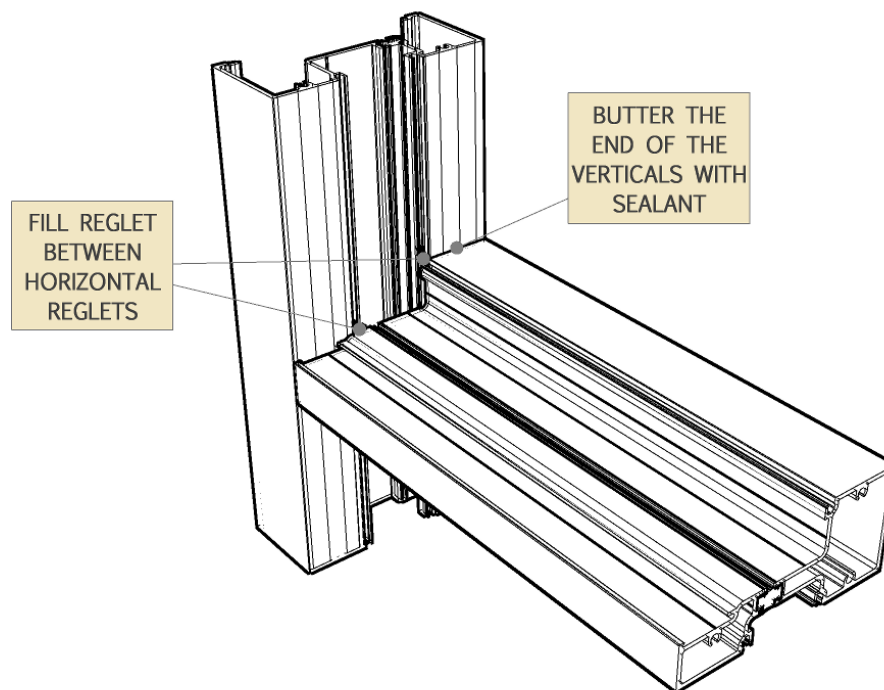

Step 2. Install the Water Deflectors.

- Peel paper and apply water deflector in place.
- Seal the edges of the deflector on all sides except the edge facing the pocket and to the front to allow drainage to flow down the Vertical to the exterior.
- Allow sealant to cure per sealant manufacturer's instructions.
- Water deflectors are not required at the head or sill.

Figure: M

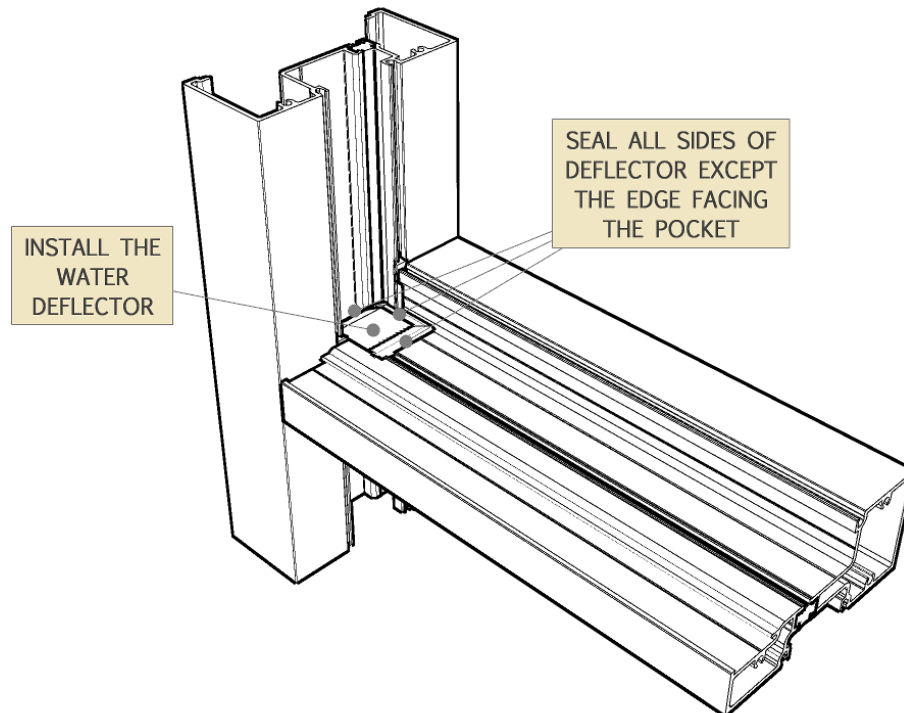

Step 3. Install Glass.

- Make sure to check dead load charts and shop drawings for correct setting block locations.
- Make sure glazing gasket reglets are free and clear of excess sealant and debris.
- Put two setting blocks in the glass pocket (2 per lite) for the glass to sit on at eighth to quarter point locations, or as defined on shop drawings.
- Put eighth inch “W” block in shallow side pocket.
- Center set glass on setting blocks. (Note: Step 4 – Pressing against the previously installed gaskets if required.) (Hint 3” spacer pieces of gasket assist in holding glass in center opposite the first side while installing gaskets.)
- Snap on the glass stop.
- Stretch half inch anti-walk block and insert from the exterior at the middle of the lite and in deep pocket verticals.

Figure: N

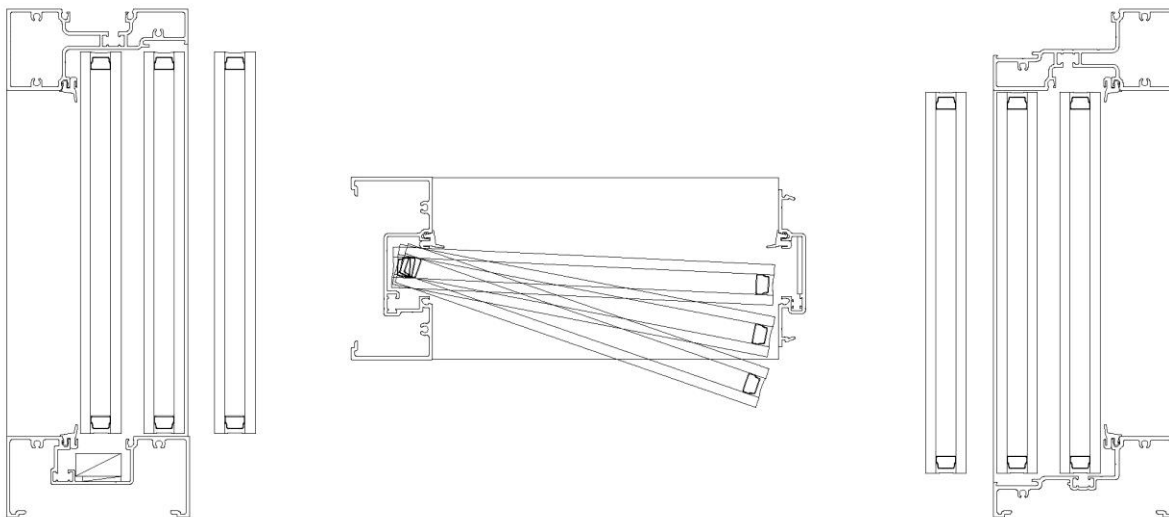

Inside Glazed
 Glazed

Outside

Step 4. Cut and Install Gaskets.

- The gaskets should be DLO X 1.02 of the member it's installing in. (Note: It may be necessary to install gasket in one side prior to setting glass, if installing at a spandrel area.)
- Butter glazing reglet 1" horizontally and vertically.
- Install vertical gaskets first to run through.
- Begin installing the gasket at the top and bottom corners of verticals. (1) & (2)
- Work from the ends of the gasket and skip to the center. (3) Continue for each wave until the gasket is flush.
- Begin installing the gasket at the corners of horizontals. (4) & (5)
- Work from the ends of the gasket and skip to the center. (6) Continue for each wave until the gasket is flush.
- Seal horizontal gasket edges to vertical gaskets.
- Seal ends of inside glazed stops. (Remove excess sealant.)
- Remember to never stretch the gasket when installing it.

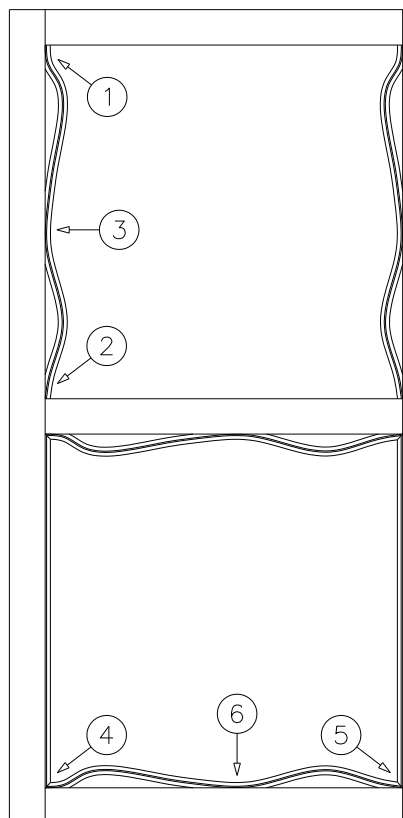
Figure: O

90 Degree Corner Installation

Step 1. Install Mitered Sub Sill.

- Fasteners on mitered corners normally use holes instead of slots to pin them in place.
- Miter sub sill and install on one side of the corner first securing it in place to the structure.
- Install the adjoining sub sill and seal the miter joint with silicone and splice tape.

Figure: P

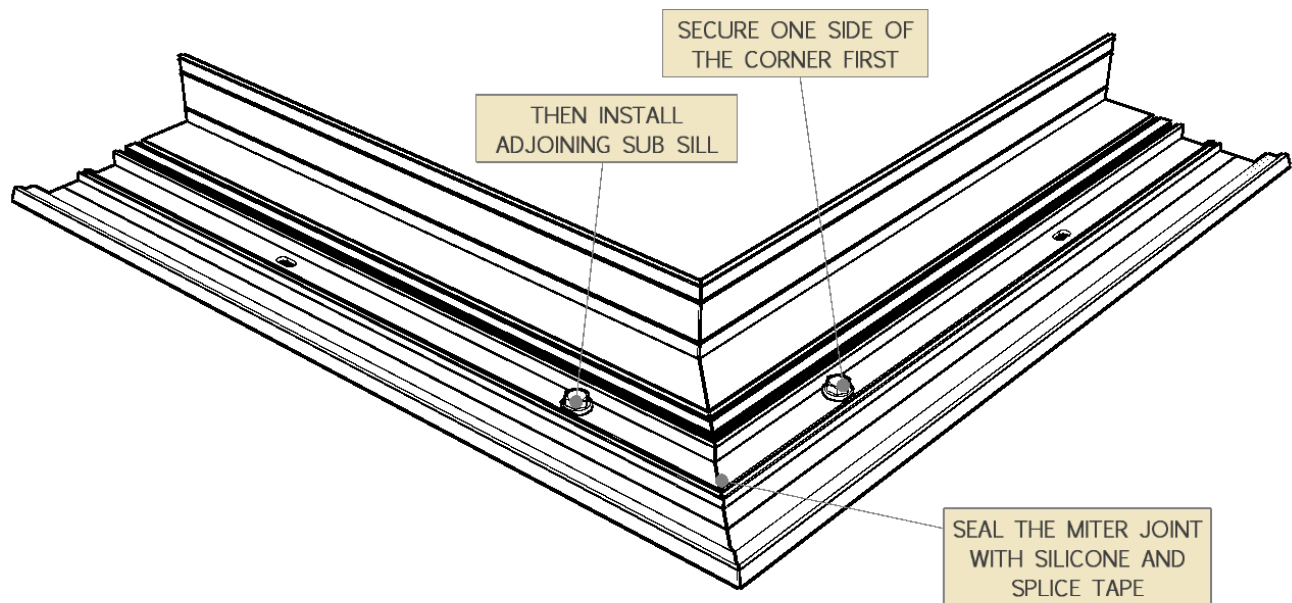

Step 2. Install Corner Mull 10117 and Corner Mull 10116.

- Install the 10117 corner mull.
- Attach horizontals and re-seal any damaged sealant at the mitered joint of sub sill.
- Slide 10116 with horizontals pre attached until snapped into place.

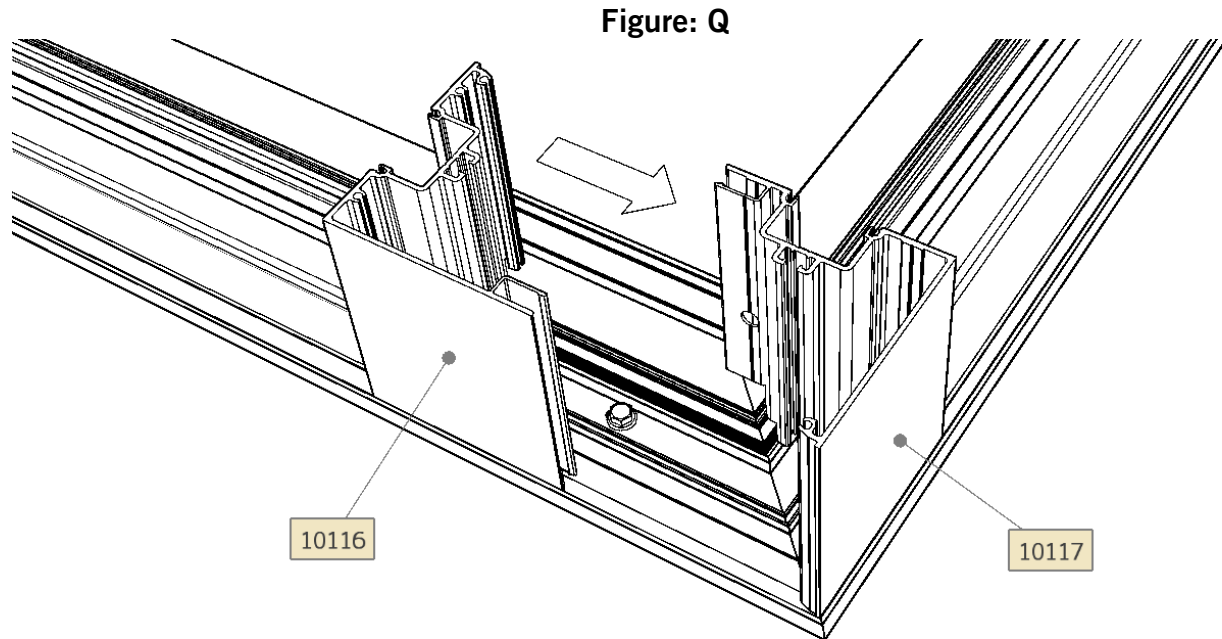

Expansion Mullions

- Expansion mullions are required to allow the system to absorb thermal expansion and contraction across long spans of fenestration elevations. Placement of expansion mullions are determined by project requirements and calculation of the materials thermal coefficients of expansion.
- Try to locate expansion mullions strategically away from corner zones and entrances so they do not interfere with other applications.
- Expansion mullions are typically designed to set around an eighth inch gap to match adjacent mullions, but should be in accordance to the temperature at the time of installation. Mullions are designed not to exceed 3/8" expansion.
- Expansion is calculated by the number of inches the material is spanning times the degrees variance of the project location times the coefficient of material expansion.
- Expansion formula using the coefficient of expansion of aluminum and approximately 60 deg. to 80 deg. expansion is nominal for an application in the 48 states. 60 deg. will cover approximately 120 deg. Variance, and 80 deg. will cover approximately 160 deg. variance.
- $E = \text{Length}'' \times \text{Variance deg.} \times .0000128$

Figure: R

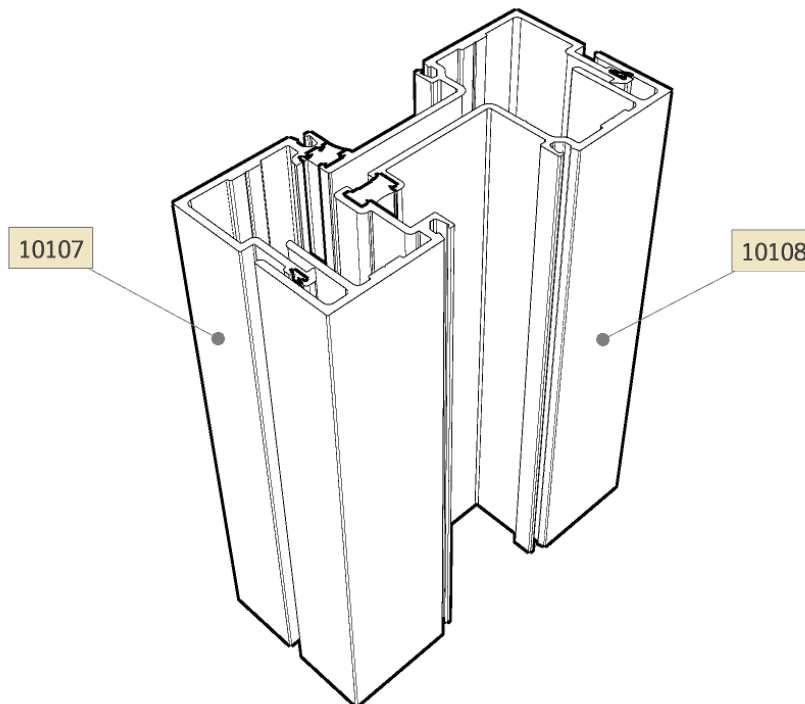

Final Step

- Inspect finished product on interior and exterior, and repair any damaged seals. (Tool and Seal all Openings.)
- Remove excess sealant and clean system for presentation.

B450 Storefront Extrusions 2" x 4 1/2" Thermal Storefront Framing

PART #	DESCRIPTION	IMAGE
10100 290"	Head / Jamb / Sill / Vertical Mullion	
10101 290"	Intermediate Horizontal	
10102 290"	Glazing Stop	
10103 290"	Sill / Head	
10104 290"	Shallow Pocket Filler	
10105 290"	Sub-Sill	
10106 290"	Thermal Mullion Filler	
10107 290"	Male Expansion Mullion	
10108 290"	Female Expansion Mullion	
10109 290"	Thermal Glazing Filler	
10110 290"	Heavy Duty Mullion	
10115 290"	Corner Mullion Cover	
10116 290"	1 Pocket Straight - Corner Mullion	
10117 290"	1 Pocket Corner Mullion	
10118 290"	2 Pocket Corner Mullion	
10119 290"	Deep Pocket Filler	
10120 290"	Shallow Pocket Vertical Mullion	
10121 290"	Transom Sash	
10122 290"	Transom Sash Stop	

B450 Storefront Accessories 2" x 4 1/2" Thermal Storefront Framing

PART #	DESCRIPTION	IMAGE
140-2278	Support Shear Block 15/16" Length	
140-2277	Small Shear Block 15/16" Length	
140-2276	Large Shear Block 1 5/16" Length	
140-2279	Channel Anchor (6")	
150-1066	#14 x 1-1/4" PHL FH SMS B SS Sub-Sill Fastener	
150-1071	#10 x 1/4" PHL FH SMS UC SS Stiffener Attachment Screw	
150-1067	#10 x 1/2" PHL FH SMS UC B SS Shear Block Pin / End Dam Screw	
150-1069	#10 x 1" PHL FH SMS SS Shallow Pocket Sash	
150-1006	#10 x 1-1/4" PHL FH SMS SS Assembly Fastener	
150-1070	#10 x 1-1/2" PHL FH SMS SS Deep Pocket Sash	
120-1231	Glazing Wedge Standard - B450 1" Glazing	
120-1219	Water Deflector 1-5/16" Length	
120-1004	Sweep Gasket Used at Expansion Mullions	
120-1222	Anti-Walk Block (Small) 1/8" Length	
120-1221	Anti-Walk Block (Large) 1/2" Length	
120-1150	Setting Block 1/8" x 1" x 4"	
120-1220	Setting Block 9/16" x 1-1/8" x 4"	
170-1053	Tape Splice Boot 0.045 x 4" Silicone	
120-1225	Setting Block 9/16" x 3/8" x 4"	
120-1232	Glazing Wedge Standard - B350 1/4" Glazing	
210-1007	Vertical Mullion Reinforcing Steel 10 ga 4-3/16" x 1-1/16" x 10"	
210-1008	Vertical Expansion Mullion Reinforcing Steel 10 ga 4-3/16" x 3/4" x 10"	
140-2259	Sub-Sill End Dam	

B350 Storefront Extrusions 1 3/4" x 4 1/2" Non-Thermal Storefront Framing

PART #	DESCRIPTION	IMAGE
10000 290"	Intermediate Horizontal Head / Sill	
10001 290"	Shallow Pocket Filler	
10002 290"	Head / Jamb / Sill Vertical Mullion	
10003 290"	Glazing Stop	
10105 290"	Sub-Sill	
10106 290"	Thermal Mullion Filler	
10008 290"	Glazing Pocket Filler	
10011 290"	2 Pocket Corner Mullion	
10013 290"	1 Pocket Straight / Corner Mullion	
10012 290"	1 Pocket Corner Mullion	
140-2280	Assembly Drill Jig Screw Boss 350	
140-2281	Assembly Drill Jig Shear Block 350	
140-2282	Assembly Drill Jig Screw Boss 450	
140-2283	Assembly Drill Jig Shear Block 450	

Let's Shine.

800.737.2800 • fax 417-862-1232 • BoydAluminum.com

©2014 Boyd Aluminum Manufacturing. The Boyd sunburst and logotype are trademarks of Boyd Aluminum Manufacturing. All rights reserved. Due to continued product research, specifications are subject to change without notice.

SFIG-24

062514